

# DATA BASED COMMISSIONING: MIT's Experience

June 3, 2010 CEE Conference

Peter Cooper, PE, CEM, LEED-AP

Manager of Sustainable Engineering and Utility Planning

Department of Facilities

Massachusetts Institute of Technology

David Landman, CEM

Chief of Energy Engineering

Cimetrics, Inc.

# MIT's Motivation

- Observed creep in energy consumption in existing buildings
- Failed/overridden equipment/controls often observed
- Maintenance budgets squeezed and efficiency a low priority.
- Technically appealing as a way to focus maintenance effort

# Data Based Commissioning Defined (aka Continuous Commissioning)

- Remote monitoring of building performance
- Interface with building control system
- Compare actual performance to model
- Specific maintenance issues identified to owner's staff monthly
- Energy saving dollar value of fixes calculated
- Fixes observable in subsequent months

# Expected and Unexpected Results

- Expected to find complex lab buildings drifting out of spec. They were, but also...
- Significant energy waste in certain buildings.
- Defects in design or construction discovered even though buildings had been commissioned.
- MIT is very pleased with our results

# Existing and new building approaches

- Working down the list of energy intensive lab buildings.
- Fixes by internal staff to date
- Will use external resources to accelerate progress.
- Cimetrics incorporated into new construction as a warrantee tool.
- The E25 heat pipe defect story.

# SCORE CARD ON DATA BASED COMMISSIONING at MIT

Thru May 2010

BUILDING		GSF	AHUs	Points	Annual Savings			
No.	Use			Monitored	Identified	Implement	Related	
18	Chem Lab	133,000	5	2013	\$ 244,000	\$ 85,000	\$ 162,000	Hood face vel.
W35	Pools	122,000	7	606	\$ 421,000	\$ 220,000		
68	Bio Lab	260000	7	541	\$ 477,000	\$ 364,000		
16/56	Bio Lab	259,000	11	4749	\$ 536,000	\$ 155,000		
NEW CONSTRUCTION								
E25	Bio Lab	152,000	Renovation: Heat pipe heat recovery monitored					
NW35	Residence	260,000	12	1097	\$ 23,000		\$ 100,000	ASDs
E14	Dry Lab	170,000						
E62	Office	210,000						
76	Bio Lab	360,000						
					\$ 1,701,000	\$ 824,000		

# Open Questions

- What form of long term monitoring to assure persistence?
- What does Recommissioning/ Retro-Commissioning see vs. Data Based Commissioning

# Actionable Information

- Energy Consumption / Relative to Baseline
- Ventilation Summaries and Statistics
- Room Comfort Summaries and Statistics
- Demand Profiling / Load Profiles
- Predict Future Baselines
- Energy Meter Aggregation
- Equipment Efficiencies
- Weather Summaries and Statistics
- Equipment Energy Usage Summaries and Statistics



# Infometrics Reports- 5 Key Components

## 1- Issue Tracking and Resolution - Track the status of issues/recommendations and their impact on operation

Issue Name	Issue #	Date Opened	Date Closed	Cimetrics Comments
Central chilled water plant is not optimized. Low $\Delta T$ in primary loop with multiple chillers running.	ABC-WC-001	8/2004	8/11/2004	As of August 11, only a single chiller was operating.
Several points are questionable or appear to be duplicates.	ABC-WC-003	8/2004		Investigate removing or replacing points not used.
Some of the air handling units are over-ventilating based on building plan design values.	ABC-WC-004	8/2004		This issue will be re-addressed when outdoor air conditions dictate.

## 2 - Impact Assessment and Prioritization – Tailored to business needs and goals.

Issue #	Safety	Code	Comfort	O&M	Savings
ABC-WC-001				■	■
ABC-WC-003				■	■
ABC-WC-004			■	■	■

# Infometrics Reports- 5 Key Components

**3-Decision Support**– Outline proposed solutions and proposed cost savings, giving the customer all the financial decision support information.

Issue Name	Issue #	Report Month/Year	Estimated Annual Savings	FY06 Savings
Central chilled water plant is not optimized. Low $\Delta T$ in primary loop with multiple chillers running.	ABC-WC-001	8/2004	\$27,122	\$27,122
Excess hours of operation for AHUs.	ABC-WC-007	8/2004	\$7,614	\$7,614
Exhaust Fans are commanded "ON" during excessive hours.	ABC-WC-018	9/2004	\$1,313	\$1,313
Economizer cycle not optimized in WC AHUs.	ABC-WC-019	10/2004	\$2,105	90% \$1,895

# Infometrics Reports- 5 Key Components

## 4-Detailed situation analysis with informative descriptions-

Includes zone, AHU and plant level performance analysis combined with industry benchmarks, regulations and customer-specific needs

To the right is an illustration of the AVERAGE number of chillers online and the OPTIMUM number of chillers online for different plant (cooling) loads during July. It appears that extra chillers are running when the chilled water plant sees between 600 and 800 tons (running 2 chillers when only 1 is necessary), between 1,400 and 1,800 tons (running 3 chillers when only 2 are necessary) and when the chilled water plant sees between 2,000 tons and 2,700 tons (running 4 chillers when only 3 are necessary).

Plant Load (Tons)	Average Chillers Online	Optimum Chillers Online
0-850	1.0	1
850-1,750	2.0	2
1,750-2,650	3.0	3
2,650-3,550	4.0	4
3,550 & up	5.0	5

## 5-Actionable Improvement recommendations-Recommended control strategies, optimization and additional hardware needs are identified

It is recommended that a **common chilled water supply temperature sensor be installed** so that total chilled water plant load can be more accurately determined. **The optimum number of chillers** is based on the central plant switch over values shown:

0-850 tons	Use (1) chiller
850-1,750 tons	Use (2) chillers
1,750-2,650 tons	Use (3) chillers
2,650-3,550 tons	Use (4) chillers
3,550 tons & up	Use (5) chillers

# Infometrics Connects Building Operations to Energy Consumption

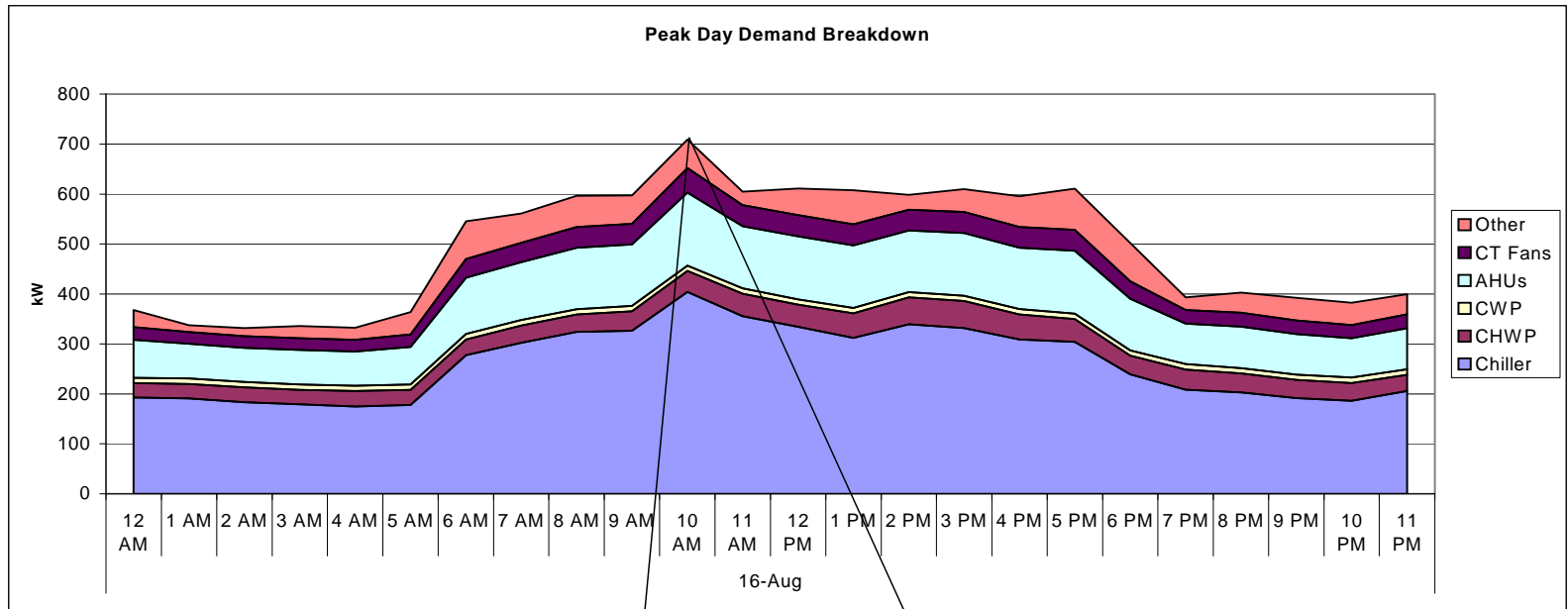

- **Analyze equipment use before, during and after peak**
- **Manage equipment to reduce future peaks**
- ***A sustainable solution offering ongoing savings***

# Analysis Applications

- Chiller Performance
- Schedule Tracking
- Setpoint Error
- Rules based analysis
- Energy Summary
- Microtrend
- Sensor Pegged / shorted
- Starved/Undersized Equipment
- Sensor Outside of Expected / Design Range
- Ineffective (leaky?) Actuator/Valve



**Problem:** Economizer issue. Mixed air temperature setpoint higher than discharge air temperature setpoint.

Utility Rates:  
\$0.16/kWh  
\$0.23/ton-hr  
\$0.017/lb

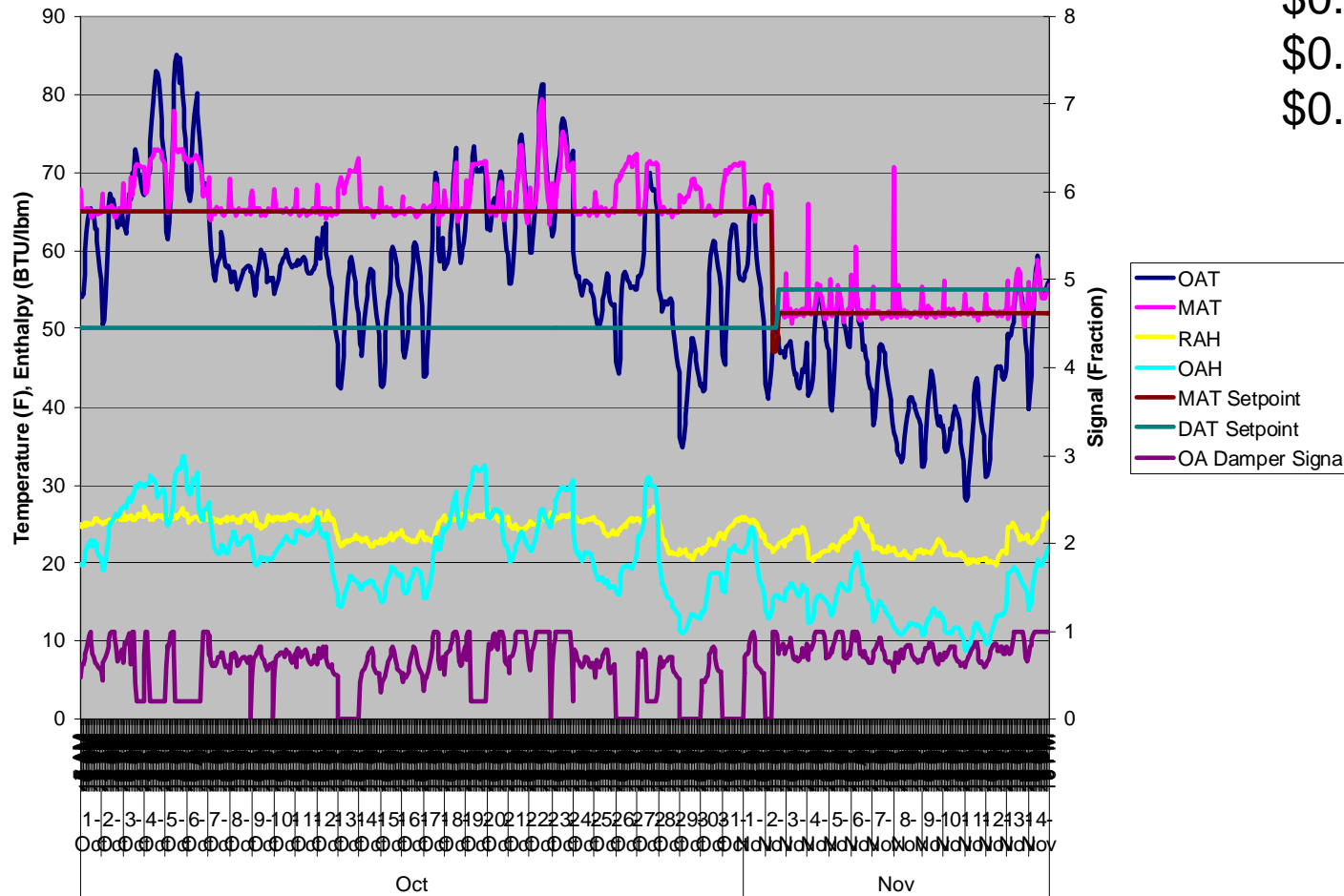

**Solution:** Adjust both Discharge and Mixed Air Temperature setpoints for cooling. Fixed November 1<sup>st</sup>.

**Results:**  
\$4,803 annual excess cost

**Problem:** Economizer issue. Mixed air temperature setpoint higher than discharge air temperature setpoint.

Utility Rates:  
\$0.16/kWh  
\$0.23/ton-hr  
\$0.017/lb

Economizer Display with Reference Line (26% Min OAF, 52F MAT\_SP, 72F OAT Economizer Changeover, 72F RAT)

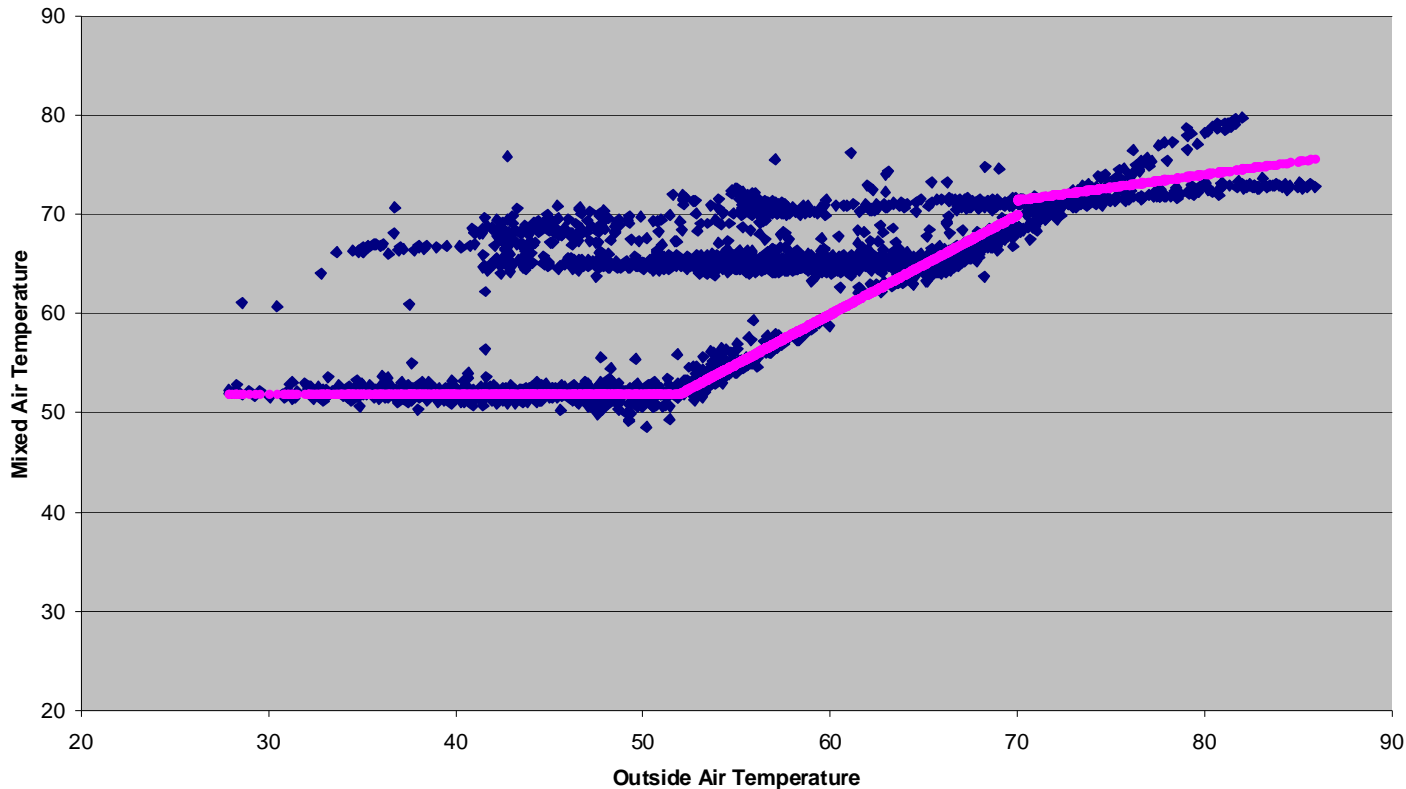

**Solution:** Adjusted both discharge and mixed air temperature setpoints for cooling. Fixed November 1st.

**Results:**  
\$4,803 annual excess cost

# Air Handler Schedule Display

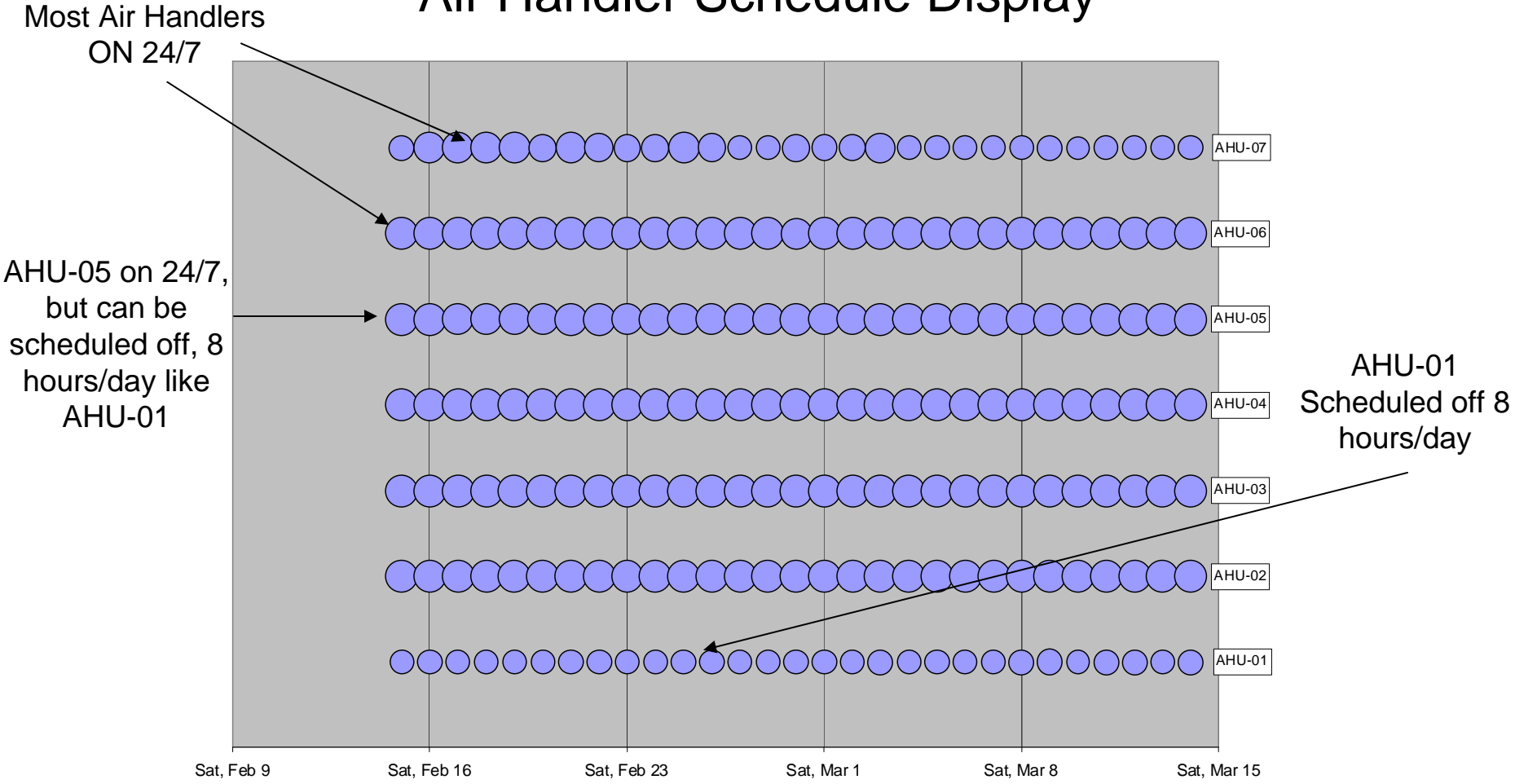

**Results:**  
\$14,273 annual excess cost

**Problem:** Cooling coil valve leaking. Valve signal is 0, closed.

Utility Rates:  
\$0.16/kWh  
\$0.23/ton-hr  
\$0.017/lb

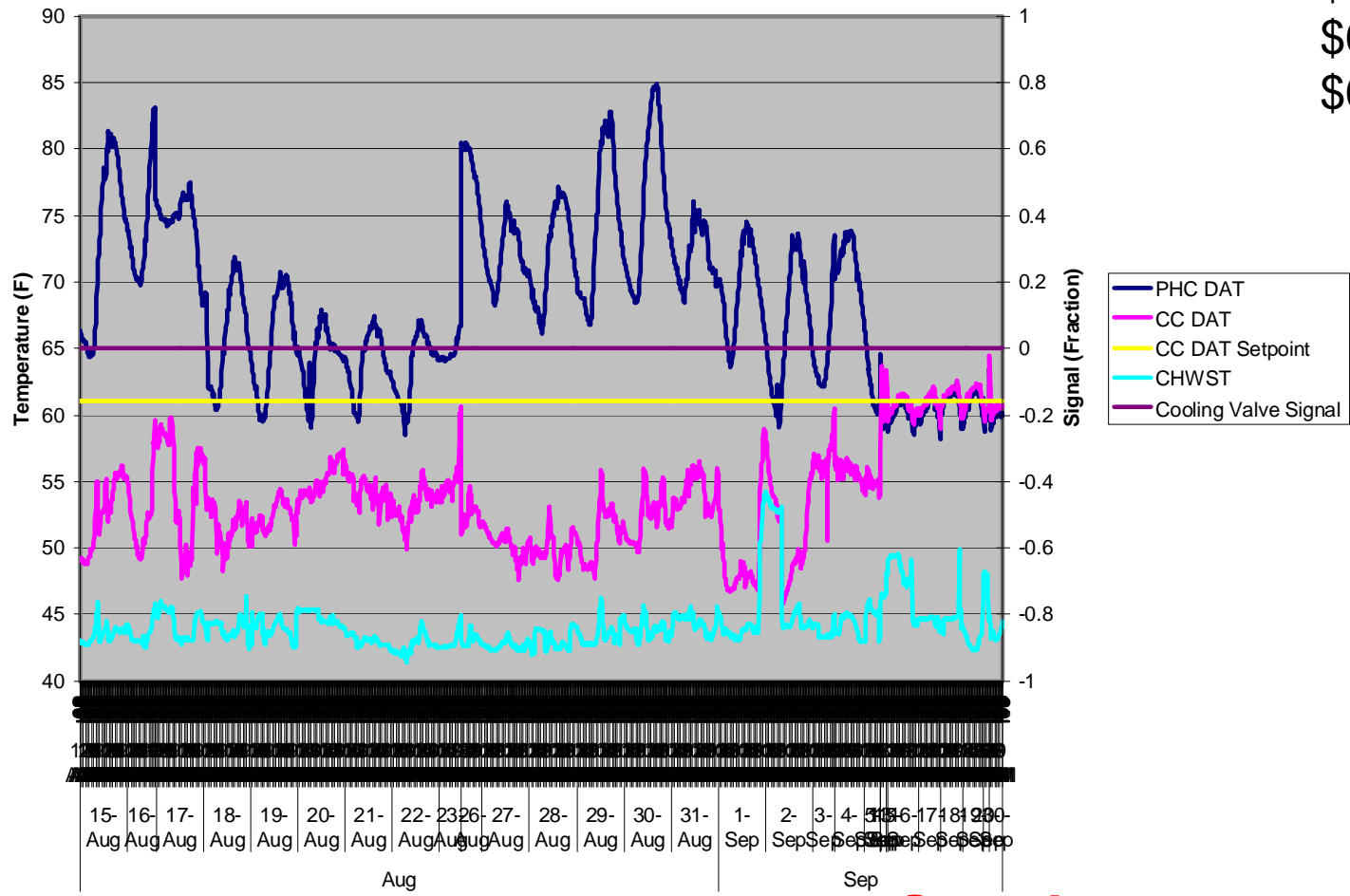

**Solution:** Replaced cooling coil valve.

**Results:**  
\$72,145 annual excess cost

# Problem: Outdoor Air Damper Closed

AHU-1: 10,000 CFM  
24 Hours/Day

Utility Rates:  
\$0.10/kWh  
\$1.50/therm

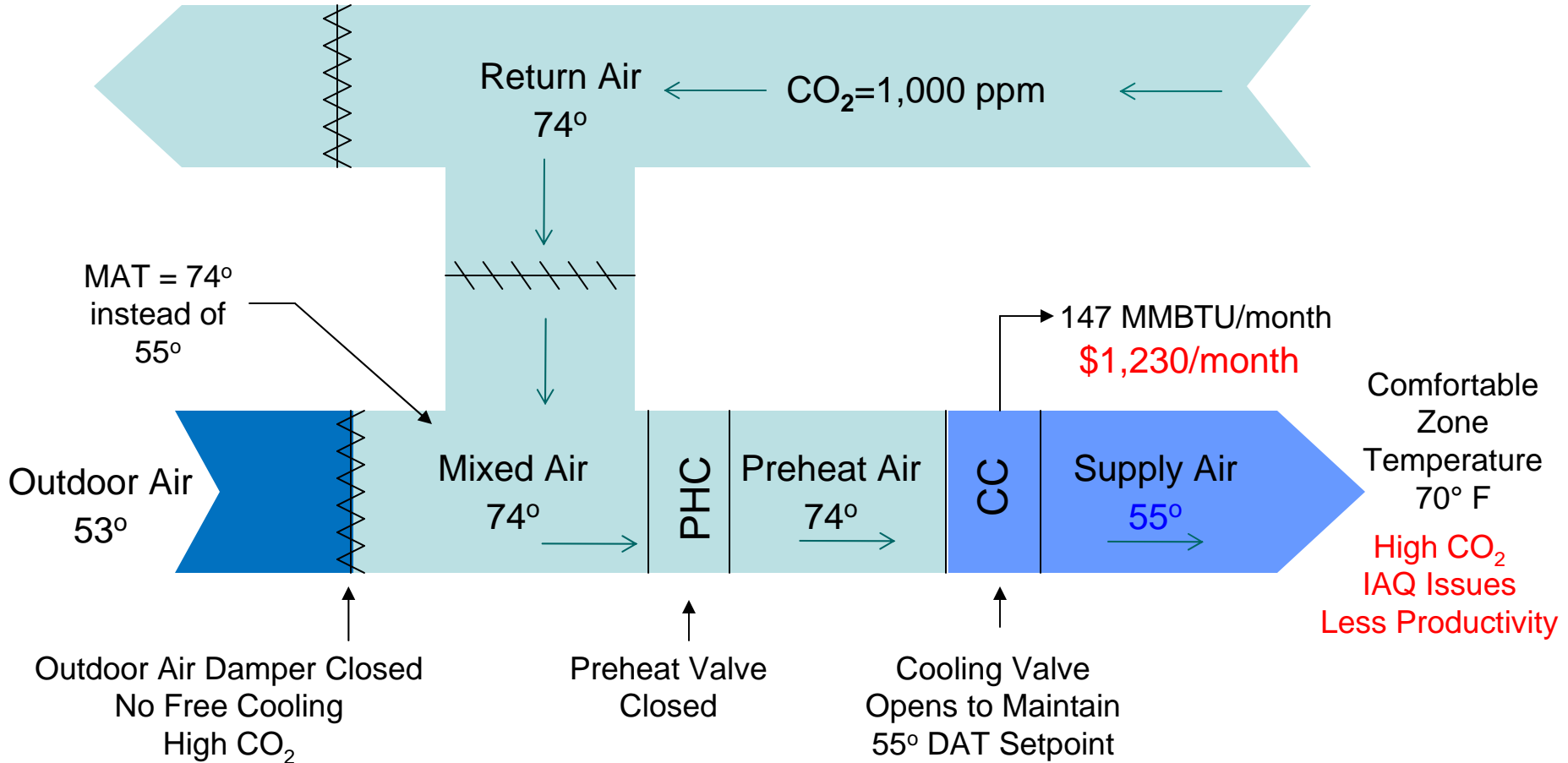

## Results:

\$7,380/month excess cost

# Problem: OA Damper Leaking

AHU-1: 10,000 CFM  
8 Hours/Day

Utility Rates:  
\$0.10/kWh  
\$1.50/therm

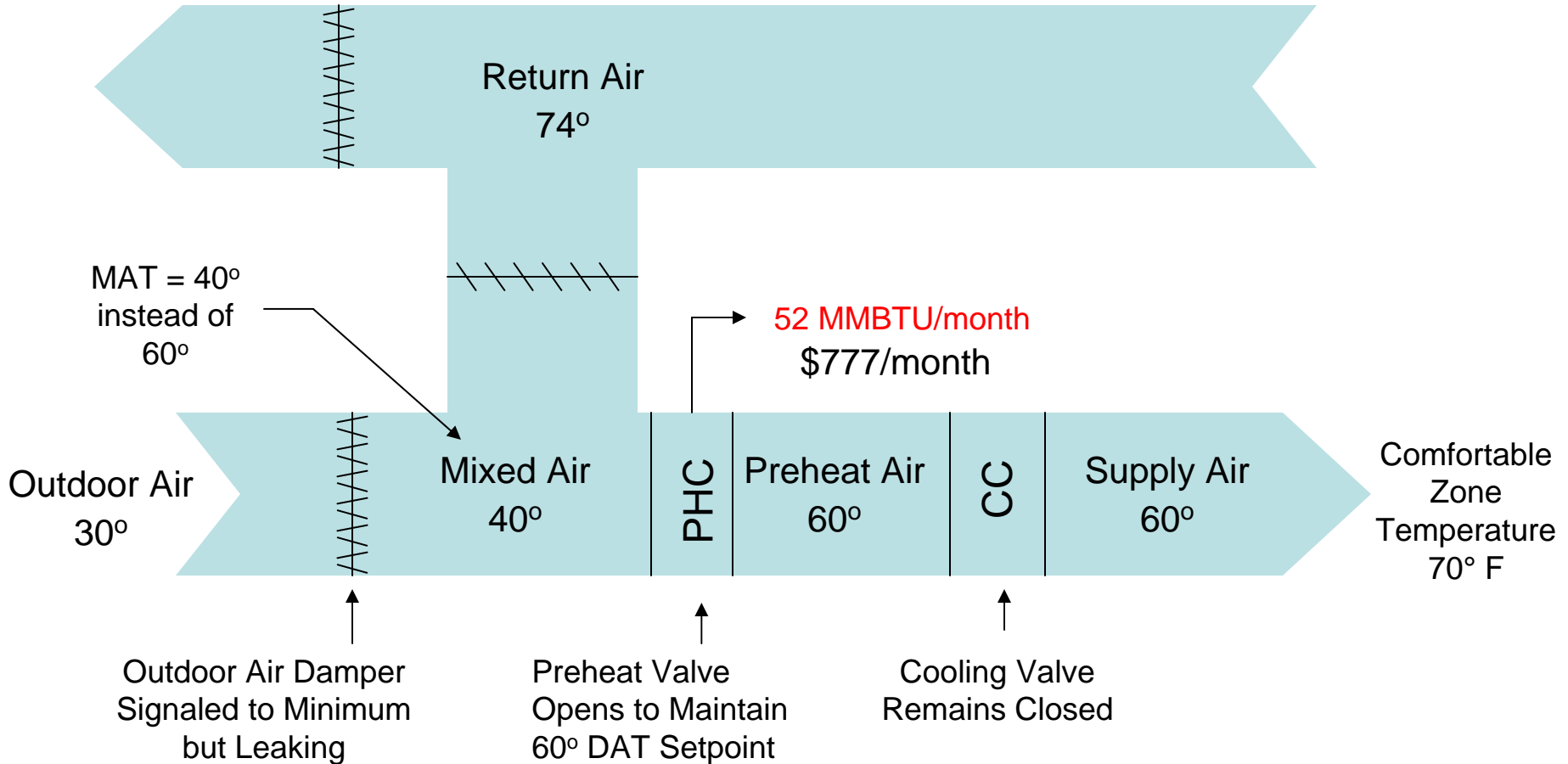

## Results:

\$777/month excess cost

# Problem: Simultaneous Heating & Cooling

AHU-1: 10,000 CFM  
24 Hours/Day

Utility Rates:  
\$0.10/kWh  
\$1.50/therm

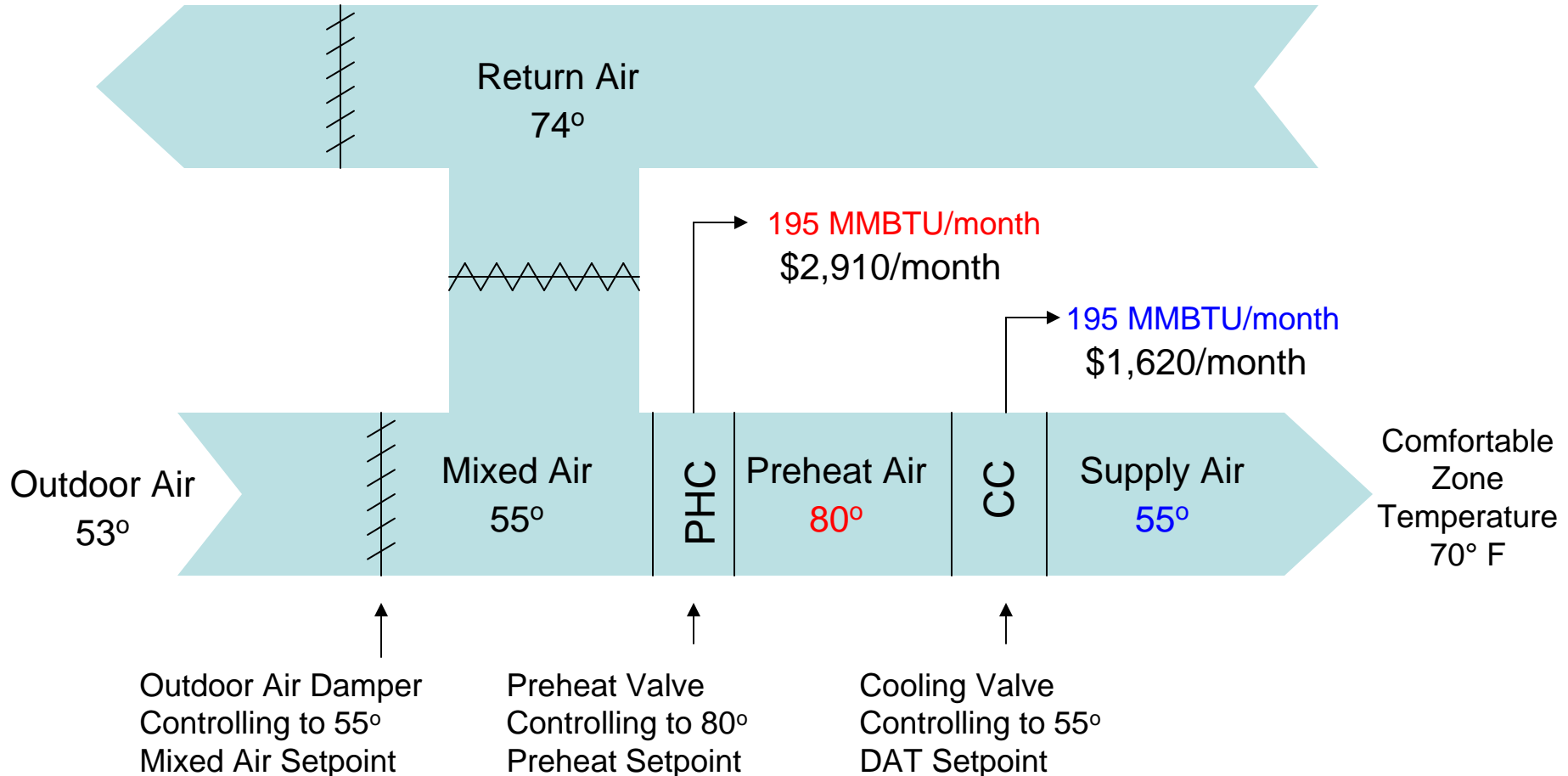

## Results:

\$4,530/month excess cost

# Air Handler Schedule Display

Most Air Handlers  
ON 24/7

AHU 4-16 is ON  
Weekdays for  
8 hrs/day

Some AHU  
Schedules  
Changed from  
24/7 to 8 hrs/day  
Weekdays Only  
on April 11th

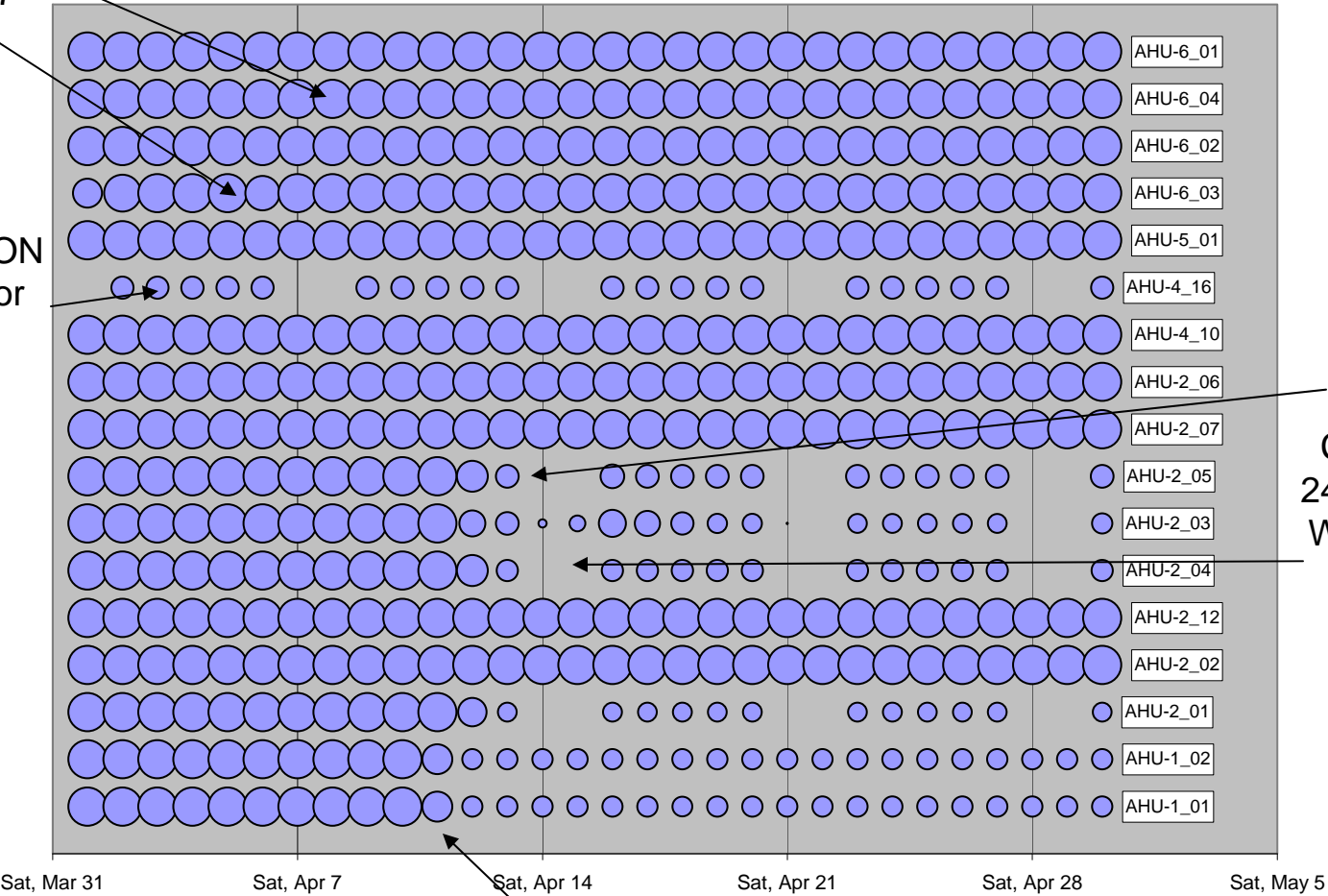

**Results:**  
\$8,250/month excess cost

AHU Schedules Changed  
from 24/7 to 8 hrs/day on  
April 11th

# Problem: Leaking Chiller Isolation Valve

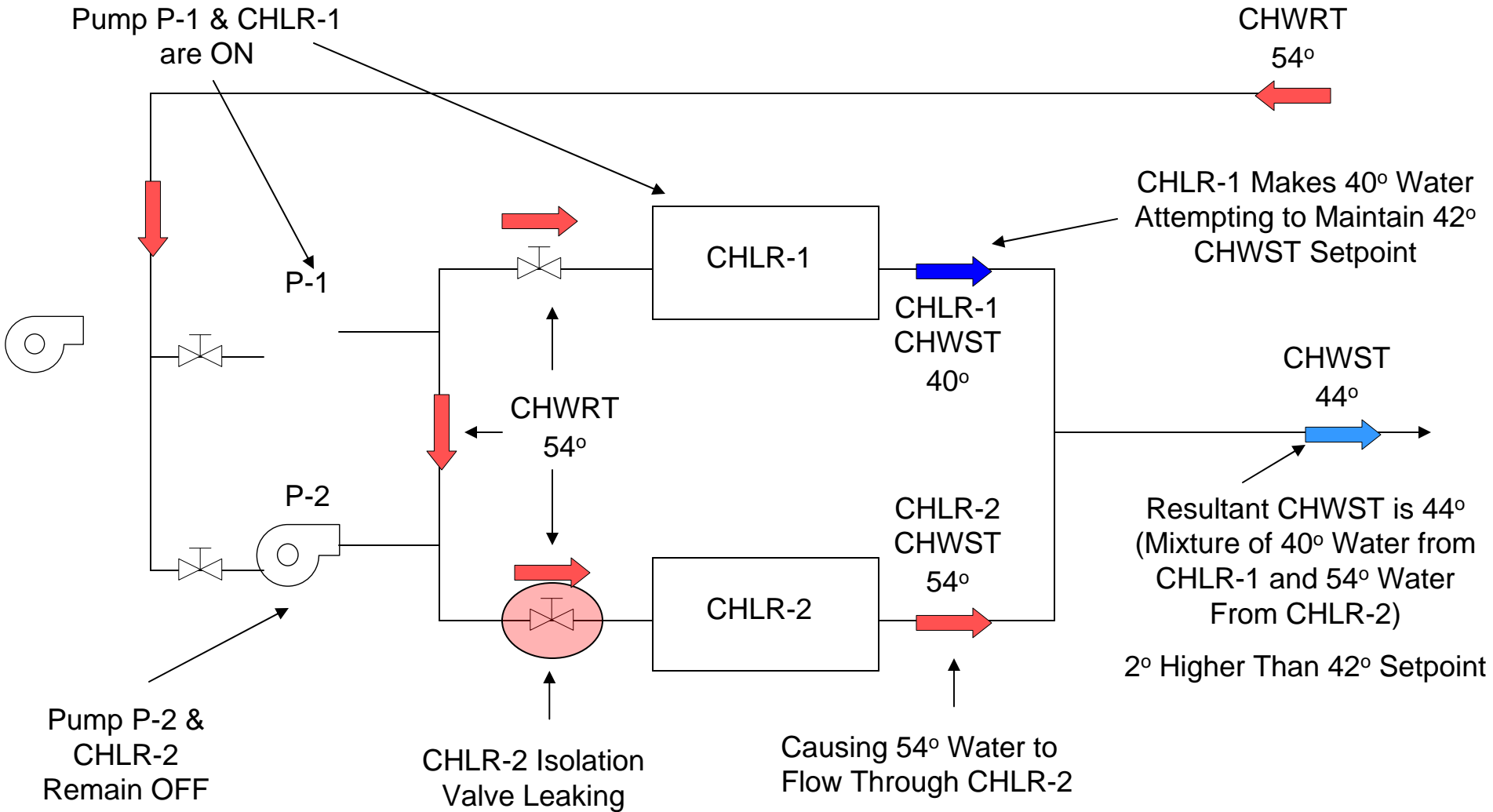

**Results:**

\$860/month excess cost

# Signal Microtrending

VAV Discharge Temperature is Ranging from 60° to 150°

VAV Reheat Valve Cycling  
*Microtrend*

VAV Reheat Valve is Cycling from Closed to 75%+ Open

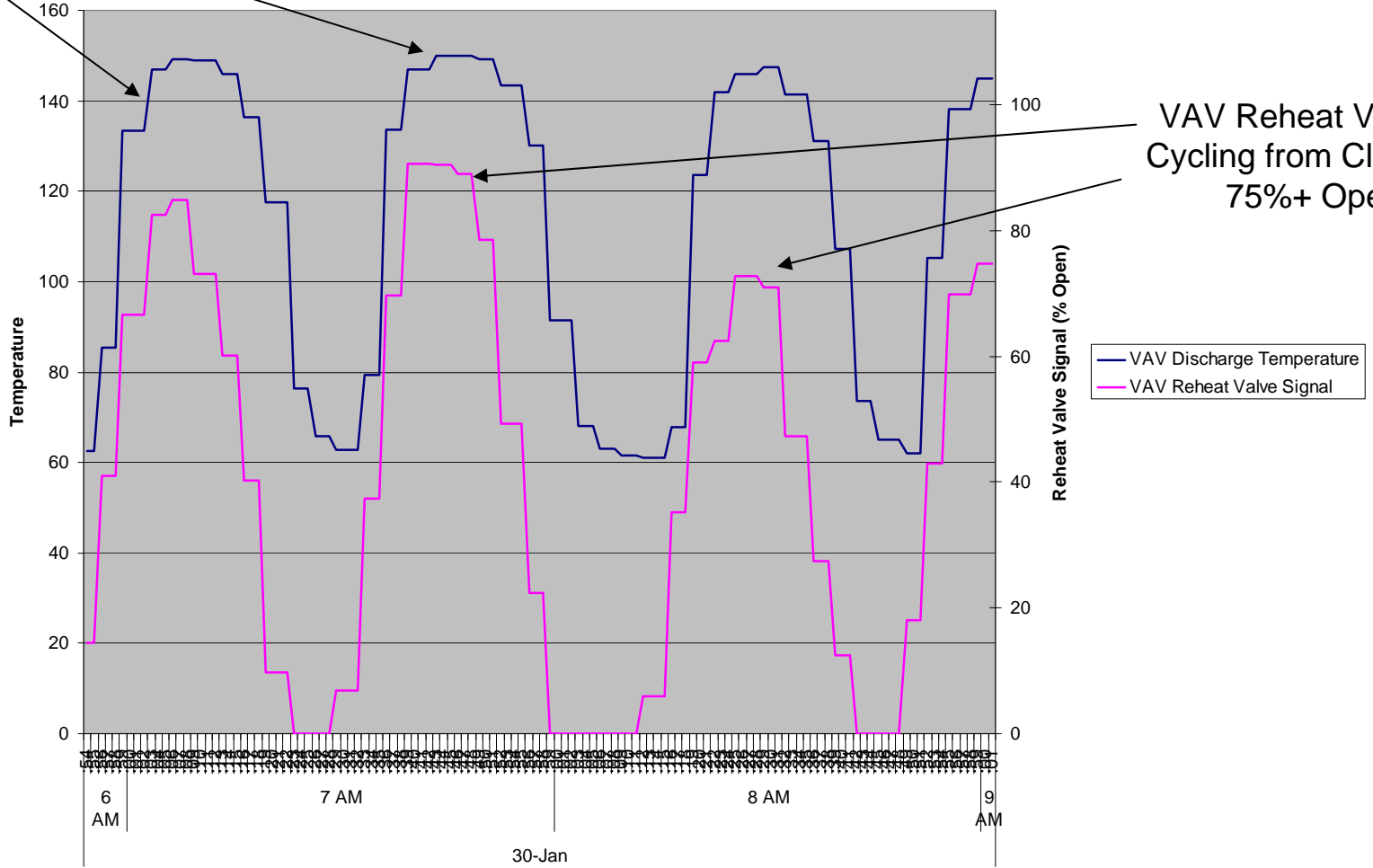

**Results:**  
Reduced O&M costs